



## MODELS: TK30BC-1 & TK30BC-2 BLAST CHILLERS

## SPECIFICATIONS

This specification covers models TK30BC-1 & TK30BC-2 roll-in blast chillers using uniframe modular chiller system from **Thermo-Kool®**.

**CAPACITY:** TK30BC models are designed for roll-in:

- Angle guide rack, up to 40 food pans
- Universal guide rack, up to 40 food pans or 20 sheet pans
- Combi oven racks
- Any size rack up to 35"(W) x 38"(D) x 75"(H)

**PERFORMANCE:** TK30BC models blast chill up to 300 lb of product from 165°F to 37°F within two hours when the remote condensing unit used is model TK30BC-CU-A or TK30BC-CU-W.

(Remote condensing unit is optional. These models can be connected to a medium temperature refrigeration rack system.)

**CONSTRUCTION:** The blast chiller cabinet is constructed of four-inch panels with a patented DURATHANE 100% urethane tongue and groove hard rail perimeter, foamed-in-place CFC-free polyurethane insulation with an exterior of polished 304 stainless steel and the interior of mirrored finish 304 stainless steel. The door is mounted to a heavy-duty reinforced steel "U" channel frame

that is foamed in place to provide additional support and rigidity to prevent racking and twisting of the door section. The door frame is heated to avoid frost buildup and is fully controlled by the unit's electronic control system.

**REFRIGERATION SYSTEM:** All required electrical and refrigeration components are fully assembled on a 304 stainless steel standalone uniframe modular chiller system which allows for quick and easy installation. The system utilizes 404A refrigerant. A unique three-way indirect airflow system within the food compartment, combined with a multipoint injection high efficiency evaporator, delivers a close gradient temperature over the product. A remote condensing unit specifically designed for blast chilling and shock freezing can be provided separately by **Thermo-Kool®**.

The uniframe modular chiller system is protected by a registered patent with the United States Patent and Trademark Office.

**CONTROL SYSTEM:** The TK30 control system is based on the latest microcontroller technology and comes standard with one food probe and one air probe that monitor temperatures and control the unit while operating in the fully automatic mode. The unit is also fully functional in manual mode. Various cycles are available: soft chill, hard chill, evaporator defrost, thaw (optional), and ultraviolet light sterilization (optional). At the end of any chill or thaw cycle, the unit will automatically switch to a holding mode to keep the product at safe temperatures. The controller has a real time clock and storage capabilities for up to 150 recipes for documentation purposes as well as a built-in dry contact for an external alarm/phone dialer connection. A two-line, 40-character display allows the operator easy on-screen step-by-step operation and programming.

**ELECTRICAL:** TK30BC-1 is 115VAC, 1Ph, 60Hz, 15 Amps circuit. TK30BC-2 is 208VAC, 1Ph, 60Hz, 15 Amps circuit.

**INSTALLATION:** A detailed installation manual and an owner's manual are provided with every unit. These manuals must be carefully followed to ensure installation and proper operation to protect the warranty.

**WARRANTY:** The warranty covers parts found to be defective and the labor required to replace them for a period of one year from the date of shipment. For full warranty details please refer to the **Thermo-Kool®** standard warranty shipped with each unit or available upon request.

**APPROVALS:** Safety approval according to UL 471 and sanitation approval according to NSF 7 as tested by ETL/INTERTEK.



**PROJECT:**

**QUANTITY:**

**ITEM NO:**

**Product Load Per Cycle:**

**Chills up to 300 lb from 165°F to 37°F within two hours**

**Required Refrigeration:**

**34,000 Btu/H (20°F Evap. Temp./110°F Cond. Temp.)  
Medium Temp., R404A**

**Refrigeration Lines:**

**1-1/8" Suction Line  
1/2" Liquid Line**

**Shipping Weight:**

**1000 lb**

**Electrical:**

**TK30BC-1: 115VAC, 1Ph, 60Hz, 15 Amps Circuit**

**TK30BC-2: 208VAC, 1Ph, 60Hz, 15 Amps Circuit**

**OPTIONS:**

- Insulated floor
- Exterior ramp
- Serial printer for complete HACCP documentation
- Label printer for complete HACCP documentation
- PC connection for complete HACCP documentation
- SD card for complete HACCP documentation
- Thaw cycle
- UV cavity sterilization
- Up to three additional food probes
- Rear door for pass-thru operation
- Remote condensing unit
- Mobile rack

**Note A:** The location of the drain line exit can be front, side, or rear and will be established according to job site requirements.

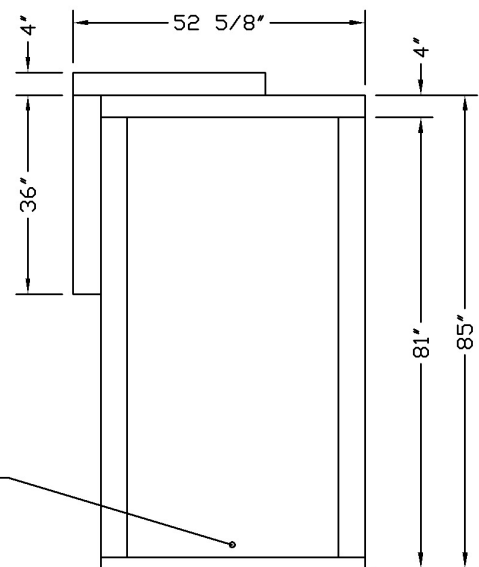
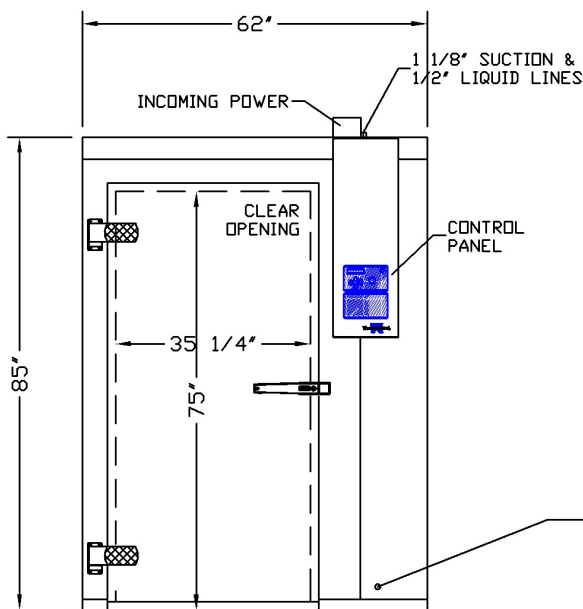
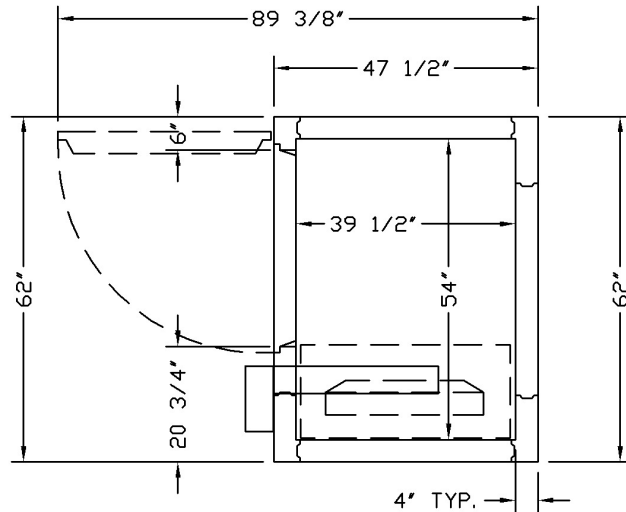

NOTE A



Thermo-Kool®

723 EAST 21<sup>ST</sup> STREET, LAUREL, MS 39440  
PHONE: (800) 647-7074  
WWW.THERMOKOOL.COM

PAGE 2

11/19/19